

TYPICAL BURNER SYSTEM ARRANGEMENTS

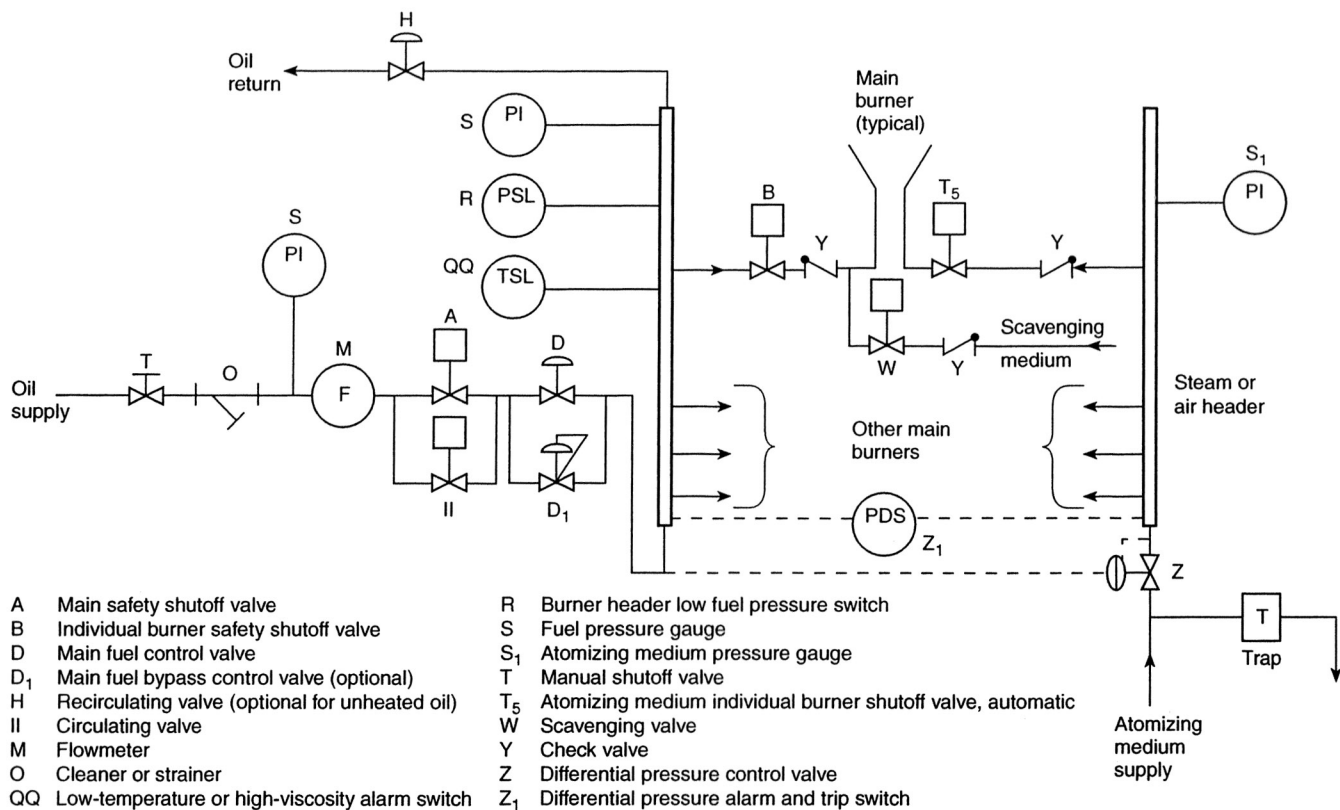

Typical Steam or Air Atomizing Main Oil Burner System