

IN-SITU OXYGEN SENSOR

Model ZP (for use with PCC-III-ZXX0 Controller)

- Reliable, long life flue gas Oxygen measurement
- Separate field mounted transmitter not required
- Simple automated calibration
- Integral Oxygen trim and boiler efficiency control logic
- Instrument air is not required

Preferred Instruments engineers and manufactures boiler control systems for commercial, industrial, and institutional facilities. Preferred's boiler control systems include combustion, feedwater (drum level), draft & flue gas recirculation control functions. Preferred's integrated control systems provide a full scope control package that assures safe and efficient control with undivided system integration responsibility.



PCC-III Controller and Model ZP Oxygen Sensor

Detector

The detector consists of a zirconia oxide cell, a ceramic heater with thermocouple, terminals for connecting to the controller unit, a flange for connection to the probe, opening to accept reference (ambient) air and a connection for calibration gas. The detector works on a principle that when heated to 800° C (1472° F), the cell generates an electrical signal directly related to the Oxygen concentration of the flue gas. Flue gases are passed through a filter to prevent dust and dirt from contaminating the cell. Calibration gas can be injected into the space behind the ceramic filter to allow on-line calibration without removal from the stack.

Probe

The probe is a stainless steel assembly that mounts on a 3" 125 lb flange (flat face) located on the flue gas duct or stack. The probe protrudes into the flue gas stream and directs boiler flue gases from the middle third of the flue gas stream to the detector. The assembly's design provides for the removal of the detector for service or replacement without the need for removal of the entire probe.

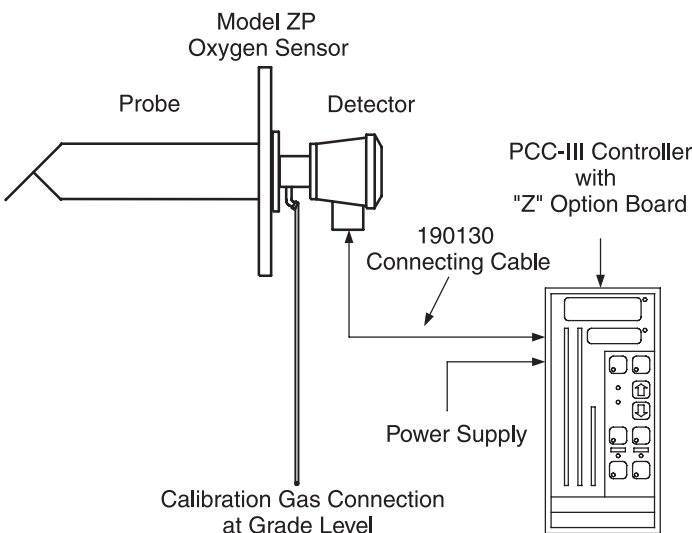

Model ZP Oxygen Analyzer Arrangement

System Specification

Gas Measured:	Oxygen in flue gases
Sensing Method:	In-situ field-replacable zirconia detector, and reliable ceramic heater
Flue Gas Temperature:	0 to 1150° F
Measuring Range:	0 to 10% standard, 0 to 21% field configurable
Accuracy:	+/- 1% of reading or 0.1% O2 (calibration gas dependent)
Response Time:	Initial 0.1 sec. / 90% 7 sec.
Power Supply:	120 Vac, 60 Hz.
Power Consumption:	82 VA total (ZP and PCC-III)
Connecting Cable:	190130. Combined signal and power cable. Up to 500 ft.

Indicating Electronics Specifications

Instrument:	PCC-III Controller. Up to two probes per PCC-III
Oxygen Trim Options:	Jackshaft, parallel positioning or fully metered combustion applications
Boiler Efficiency:	Logic included. Optional flue gas temperature T/C required.
Oxygen signal:	4-20 mAdc, Linear, Modbus RS485. (Blockware dependent)
Ambient:	32-130° F
Case:	Weather-proof front panel
Power supply:	115 Vac, 60 Hz.
Display:	4.5 Digit LED numeric display, 6 status LEDs

PCC-III "Z" Option Board Specifications

Isolated Inputs:	- Probe mV Input - Probe Heater Type R T/C Input - Spare Type J T/C Input
Output:	Fused 120 Vac heater supply

IN-SITU OXYGEN SENSOR

Model ZP (for use with PCC-III ZXX0 Controller)

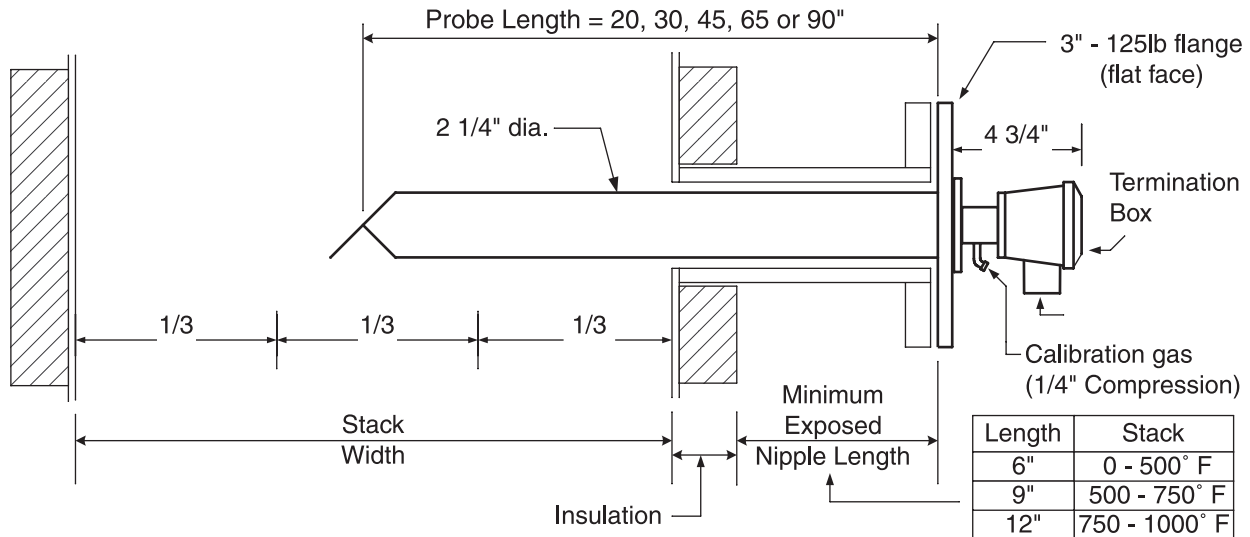

Select a probe length that positions the probe tip in the middle third of the stack

Probe Specifications

Application:	Natural Gas, Fuel Oils
Sample gas:	0 to 1150° F
Flanges:	ANSI 125 #, 4 bolt, 3 inch flange
Probe lengths:	20, 30, 45, 65 or 90 inch
Wetted parts:	304 stainless steel, alumina, quartz, zirconia, platinum
Weight:	Probe of 20 inch length approx. 18 lb.
Life of Zirconia Cell:	Typically 3-4 years (1 year warranty)
Construction:	NEMA 12
Options:	<ul style="list-style-type: none"> - 190130 Connecting Cable, (requires 1/2" conduit minimum) - 90157 Flame Arrester - 90159 Rain Shield for outdoor installation - EPA CEM Auto Calibration Package

Suggested Specification

Provide a boiler breeching mounted in-situ, zirconium oxide Oxygen analyzer for each boiler. Extractive or "Wet Cell" type Oxygen analyzers are not acceptable. The probe shall be of a suitable length to sense the Oxygen level in the middle 1/3 of the breeching. All wetted parts shall be stainless steel. The Oxygen analyzer shall include a digital controller that performs continuous self-diagnostics with diagnostic codes for at least 10 common faults. The system shall automatically send the trim actuator to the "null" position and trigger the alarm dry contacts in the event of an Oxygen analyzer fault. The detector shall be field replaceable without removing the probe from the stack and shall not require special tools. The analyzer shall automatically perform periodic detector cell impedance tests to be used by the operator as an indication of calibration shift. Analyzer calibration shall be pushbutton semi-automatic (no trim pots) with English language prompts and diagnostic messages. Analyzer output shall be field selectable as 0-10% or 0-21% without field re-calibration.

Ordering Information

1. Specify Probe Length; ZP-20, 30, 45, 65 or 90 inch
2. Specify Special Cable, p/n. 190130 length, maximum length 500 feet
3. Specify PCC-III Controller Model Number PCC-III-Z x x 0 (See Page 196)
4. Specify optional flue gas temperature element (required for boiler efficiency calculation)