

# FLUE GAS TEMPERATURE MONITOR & CUTOUT

Model JC-15D

## Low Boiler Efficiency Alarm Message and Contact

- Elevated stack temperature will indicate reduced boiler efficiency
- Every 40° F increase in flue gas temperature results in an approximate 1% decrease in boiler efficiency

## Burner Shutdown Contact and Message

- Dangerously high temperatures place the boiler at risk of serious overheating damage
- Provides additional protection against mud-filled low water cutout float switch failures
- "Three out of every four accidents are caused by overheating, and 80% of the overheating losses resulted from continued firing with low water levels; despite the fact that boilers, ... are equipped with up-to-date controls."

(from M.P. Bragg and S.R. Laskey, "Low Water Accidents," The Hartford Steam Boiler Inspection and Insurance Co.)

## High Visibility Bargraph and Numeric Display

- 4 Digit Numeric Display
- 200 Segment Bargraph
- Bargraph Alarm Setpoint Markings
- High Intensity, Long Life LED Backlighting

## Field Adjustable using English-Language Menus

- Inputs: Type J or K Thermocouple
- 4-20 mADC Output Scaling
- Fahrenheit or Centigrade
- Bargraph Scaling
- Alarm Modes, Setpoints, Deadbands, and Time Delays

## NEMA 4 Front Panel

## Flexible Communications for Data Logging

- 4-20 mADC Temperature Re-transmission
- RS485 Modbus Interface

## **Description**

The **JC-15D Flue Gas Temperature Monitor** is a microprocessor-based indicating instrument for use with a heavy duty thermocouple assembly. Flue gas temperature is continuously displayed using a highly visible backlit LCD display. An intuitive bargraph display and alarm messages provide clear stack temperature status. Bargraph Scaling, Alarm Setpoints, and Time Delays are all field selectable. All adjustments can be made directly from the faceplate of the instruments by scrolling through user friendly, English language menus.

The Type J Thermocouple Assembly is constructed of a seal welded inconel sheath for corrosion protection, and can be directly installed in the boiler's flue gas outlet. The unit includes a ½" male NPT process connection, cast iron head with thermal block, and ½" female NPT electrical connection.



JC-15D Faceplate and Display

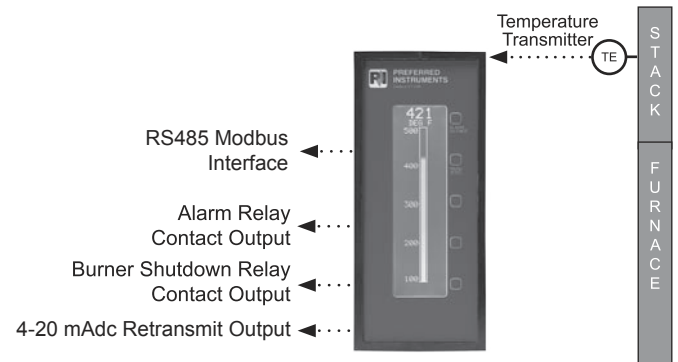

Typical Arrangement



Thermocouple Assembly Model 104087D

# FLUE GAS TEMPERATURE MONITOR & CUTOUT

Model JC-15D

## Alarm Sequence

Bargraph and numeric displays continuously indicate the flue gas temperature. If the flue gas temperature exceeds the Warning Setpoint for more than 30 seconds (adjustable), the bargraph blinks, the WARNING message appears, and the Alarm Relay energizes. If the flue gas temperature continues to increase and exceeds the Shutdown setpoint for more than 30 seconds (adjustable), the bargraph blinks, the SHUTDOWN message appears, the Shutdown relay de-energizes and latches into "Manual Reset" mode. The burner shuts down if the **JC-15D** Shutdown relay is wired into the burner interlocks. The Shutdown Relay remains de-energized and the SHUTDOWN message remains on the display until the Operator presses the RESET pushbutton.

The Alarm Relay can be used to activate an external bell or horn. The Alarm Relay de-energizes when the Warning and Shutdown Alarms are both inactive. Alternately, pressing the **JC-15D** Alarm Silence pushbutton, or energizing the 120 VAC Alarm Silence input, or a Modbus command can de-energize the Alarm Relay in order to silence an audible alarm.

## Suggested Specifications

Provide a remote reading microprocessor-based flue gas temperature alarm and indicating instrument and a flue gas temperature sensor assembly for each boiler. The instrument shall provide a flue gas temperature display in engineering units, "Inefficient" operation warning indication, "Overheat" operating condition indication and alarm contacts. The Instrument shall continuously indicate flue gas temperature on a highly visible backlit LCD display. Provide an integral or separate 4 inch, 0.5% resolution (minimum) bargraph display in engineering units with visual alarm setpoint indication. Provide an "Alarm Silence" and "Manual Reset" pushbutton and two 10 ampere relays. The housing shall be panel mountable, fully gasketed with NEMA 4 front face. All adjustments shall be made from the front panel display in engineering units. No external configuration tools shall be required. The Instrument shall provide: cold junction compensation and upscale thermocouple break protection. The Instrument shall include alarm messages as follows: When flue gas temperature exceeds the "Warning" setpoint for more than 30 seconds (adjustable), the bargraph shall blink, and the "Warning" message shall appear and an "Alarm" relay energizes and if wired to an alarm circuit an alarm is activated. If the flue gas temperature continues to increase and exceeds the "Shutdown" setpoint for more than 30 seconds (adjustable), the bargraph blinks, the SHUTDOWN message appears, the "Shutdown" relay de-energizes and latches into the "Manual Reset" mode. If the "Shutdown" relay is wired into the burner interlocks, the burner shuts down. The "Shutdown" relay remains de-energized and the "Shutdown" message remain on the display until the operator presses the integral "Reset" pushbutton.

Provide a Flue Gas Temperature Sensor Assembly for each boiler. The sensor assembly shall include: iron/constantan ISA Type J thermocouple, inconel sheath, 1/2" male NPT process connection, cast iron head and a 20" insertion length. Extension lead wire shall be one continuous length of 20 gauges ISA Type JX with PVC insulation. The assembly shall be installed in the boiler outlet before any damper or fan in accordance with manufacturers suggested installation instructions. The Instrument shall include a RS485 Modbus network interface and a 4-20 mADC retransmit output to communicate to a future Data Acquisition System (DAS) or Building Automation System (BAS). The Instrument shall be manufactured and labeled in accordance with UL508 requirements (CSA C22.2 #14 for use in Canada). Inspection and labeling shall be supervised by UL or other OSHA approved Nationally Recognized Test Lab (NRTL). The Flue Gas Temperature Monitoring, Control and Alarm System shall be Preferred Instruments, Danbury, CT, **Model JC-15D**, with **104087D** Thermocouple Assembly.

# FLUE GAS TEMPERATURE MONITOR & CUTOUT

Model JC-15D

## Specifications

### Panel

Power Supply: 120 VAC, +/- 15%, 50/60 Hz, 15 VA  
Case Size: 8" H x 3.5" W x 7.5" D  
Enclosure Type: NEMA 4 faceplate  
Ambient Temp.: +32° to 122° F  
Displays: High Contrast LCD Display  
4" high, 0.5% Resolution Bargraph  
Bargraph Range: 0°-2000° F field adjustable  
Alarm Setpoints: Two (2) adjustable with adjustable time delays

### Inputs

Input Types: Type J or Type K Thermocouple, field selectable  
Accuracy: 0.005% Resolution  
0.07% Accuracy  
Break Protection: Upscale

### Outputs

Relay: Two SPDT Relays 10 A resistive, 8 FLA, ½ HP, 120 VAC  
Retransmit: 4-20 mA DC, 650 ohm load maximum  
Network: 1200 - 38400 Baud; RS485 Modbus, ASCII or RTU

### Thermocouple

Assembly: Type J ungrounded  
Probe Material: Inconel  
Insertion Length: 20"  
Connection: ½" MNPT

## Ordering Information

1. **JC-15D** Instrument
2. **104087D** Type J Thermocouple Assembly
3. **92088-J-B20PP** Shielded type J thermocouple wire (specify wire length in multiples of 25 feet)
4. Optional Accessories:  
**SDA-B6** Alarm Bell. 85 db, weather-proof  
**SDA-VB** Remote Audible/Visual Alarm

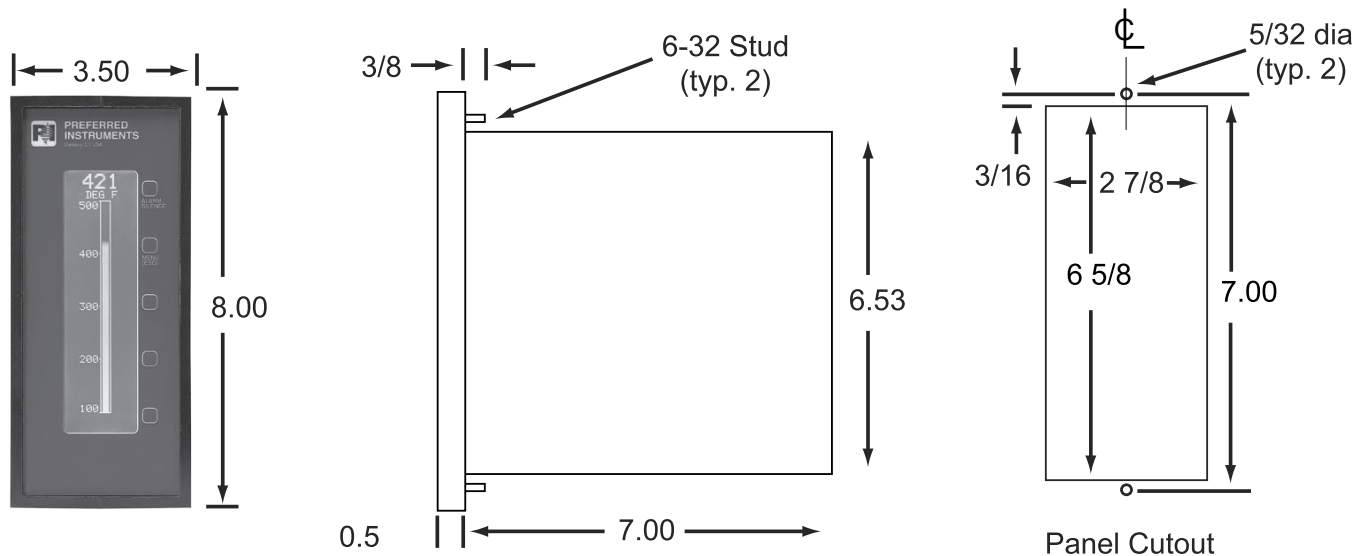

JC-15D Mounting and Clearance Dimensions